

# APM PRO

200

User Manual



# Content

<b>Components</b>	3
<hr/>	
<b>H/W Parts</b>	
Device Functions	4
Power On/Off	5
Battery / Status LED Indication	6
<hr/>	
<b>System Settings</b>	
Date & Time	7
Wi-Fi	8
<hr/>	
<b>Application</b>	
Application Settings	9
Customer	10
Switching lens Hair Analysis (APM PRO 202 Lens)	11
Hair Loss Status	12
Scalp Status	13
Hair Density	14
Keratin of Scalp	15
Exposure of Scalp's Vessel	16
Switching lens Hair Analysis (APM PRO 203 Lens)	17
Hair Thickness	18
Hair Pore Status	19
Switching lens Hair Analysis (APM PRO 204 Lens)	20
Cuticle Status	21
Summary	22
Send Result -Email	23
Mirroring	24
View Mode	26
<hr/>	
<b>Troubleshooting &amp; FAQ</b>	27
<b>Warranty</b>	29

# Components

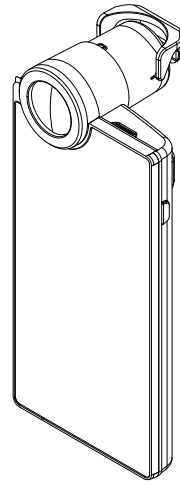
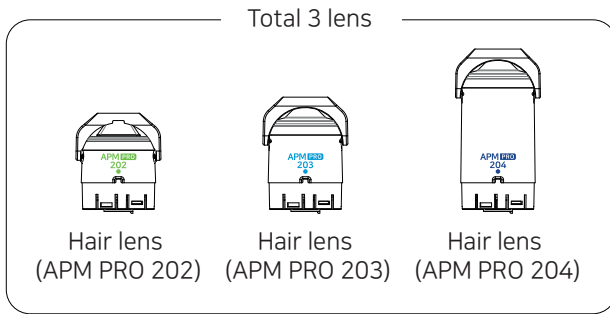

Main unit with hair lens  
(APM PRO 200)

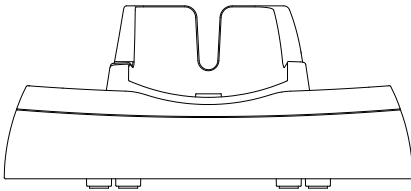

Cradle

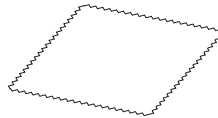

Cleaning cloth

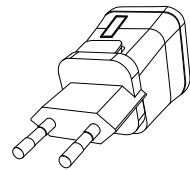

Charger

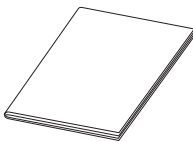

Manual

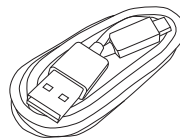

USB cable

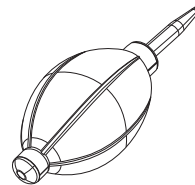

Air blower

# Device Functions

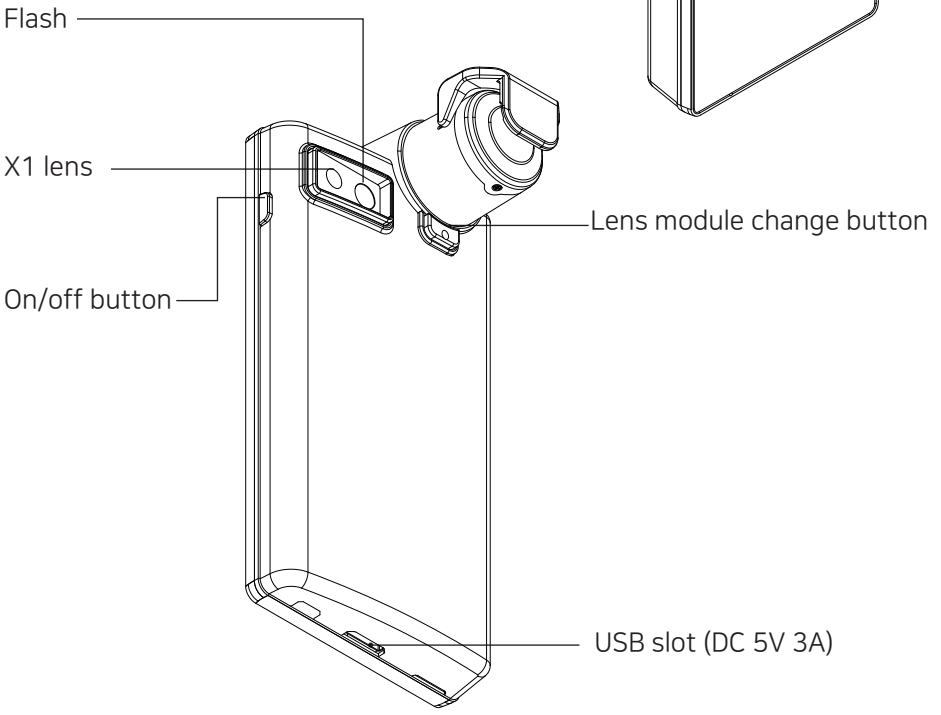
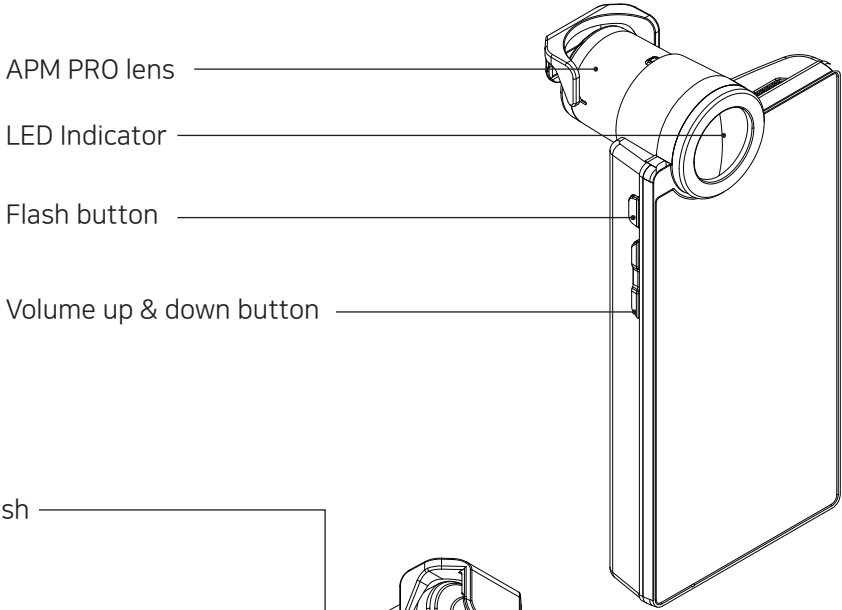

# Power On/Off

To turn on & off the power

- 1 Press the power button and hold.
- 2 Then "LED Indicator" will be twinkle and turn to white.

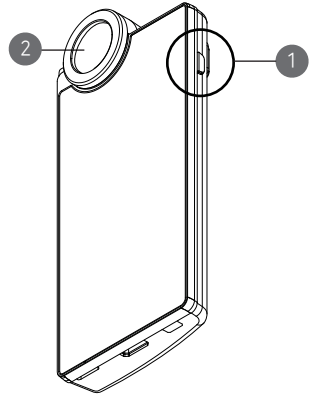

Charger can be used for American type & European type. The default is European type.

- 1 Push the plug up.

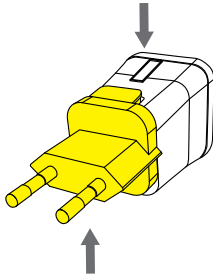

- 2 Then European type is disassembled and you can see the American type inside of the charger.

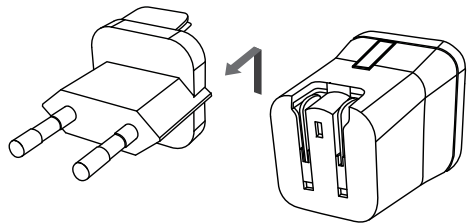

- 3 Choose the one you want to use and connect USB cable in adaptor.

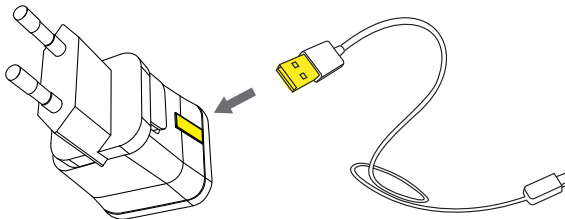

# Battery / Status LED Indication

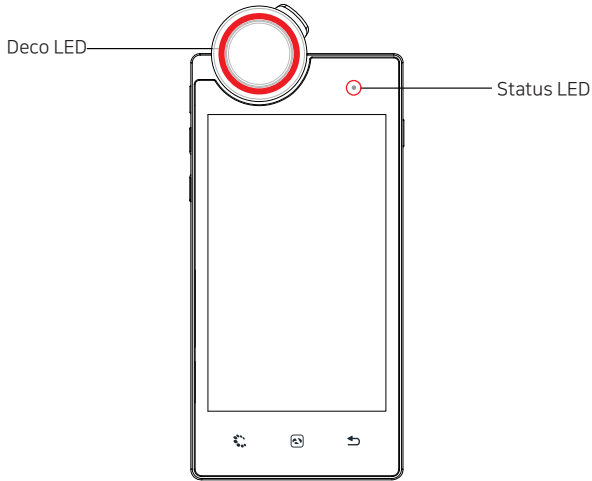

CAMERA POSITION	STATUS	DECO LED	STATUS LED	
			Light	Color
In use	While turning it on	Light on	Blue light	●
In use	When running the app	Light on	Off	●
In use	Low battery	Displayed only on the indicator at the top of the LCD screen		
Plugged to the base	Charging	Off	Red light (When the LCD screen is off)	●
Plugged to the base	Fully charged (180 minutes)	Off	Blue light (When the LCD screen is off)	●

# Date & Time



1 Press  button.



2 Touch  button.

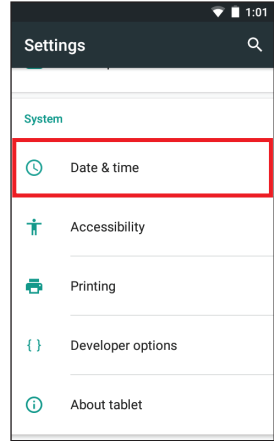

3 Touch "Date & time".

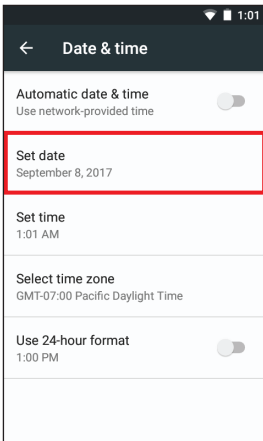

4 Touch "Set date".

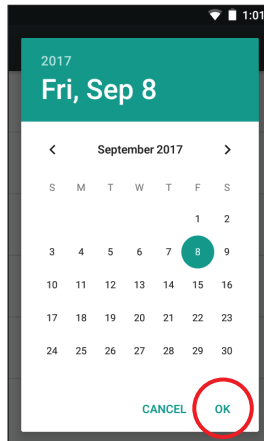

5 Change the date and touch "OK" button.

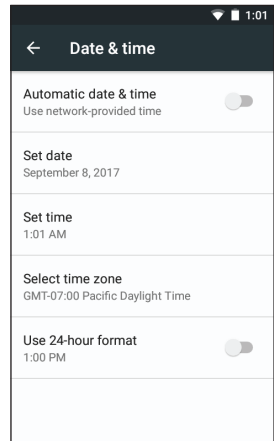

6 Please check the setting is correctly applied.

# Wi-Fi



1 Touch  button.

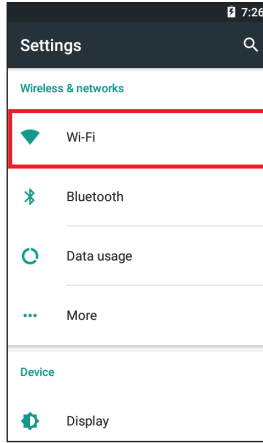

2 Touch "Wi-Fi".

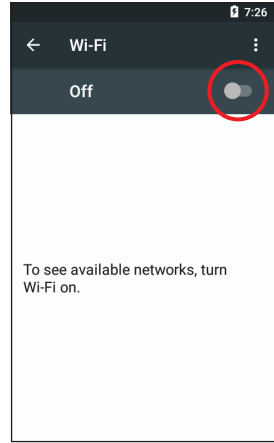

3 Turn on toggle switch.

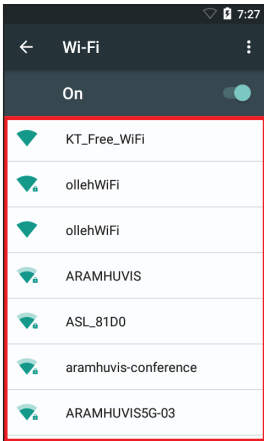

4 Wi-Fi list will appear.

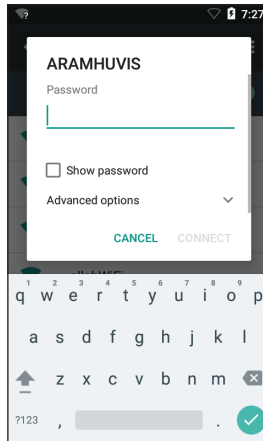

5 Among the lists, select the Wi-Fi connection you could use.

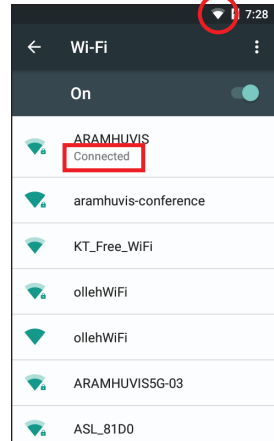

6 Wait until the device is connected to Wi-Fi.



# Application Settings



① Press ≡ button.

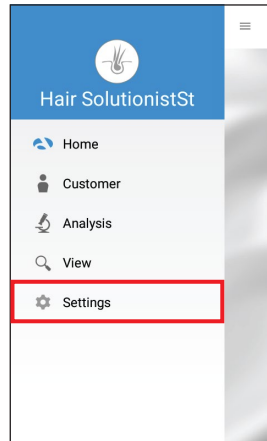

② Go to "Settings".

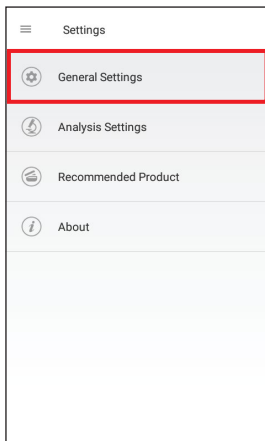

③ Go to "General Settings".

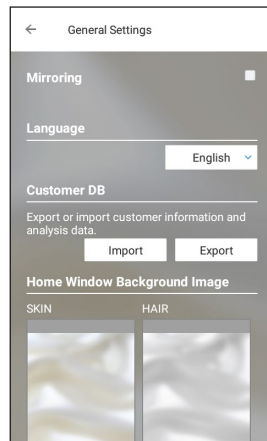

④ Language, version, CRM data Import, Export, Background Setting.

# Customer

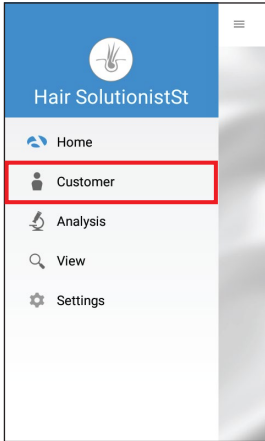

① Touch "Customer".

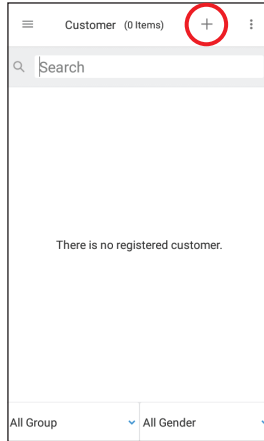

② Touch + to register new customer.

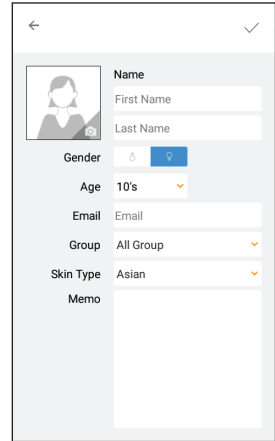

③ Input the information.

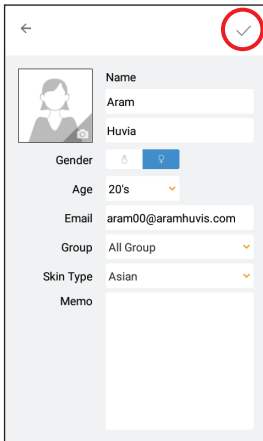

④ After putting all information, touch ✓.

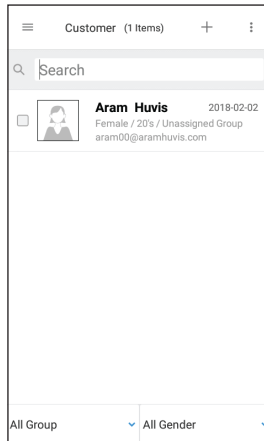

⑤ When user`s profile was created on the list. Touch user`s profile to start analyzing.

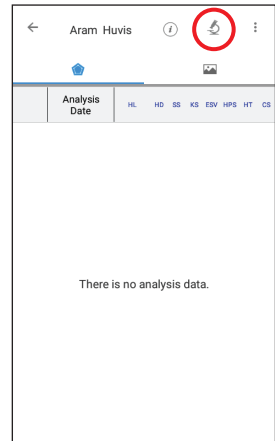

⑥ Touch  button to start analyzing.

# Taking off the lens

APM PRO-202

- 1 Press the lens module change button which located below of the lens part.

- 2 The lens will be able to pull out.



Hair lens  
(APM PRO 202)

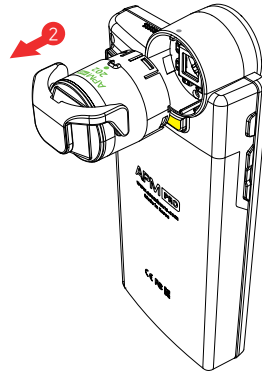
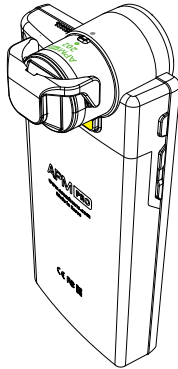

# Inserting lens

- 1 Until the correct lens is inserted, lens indicating label will blink.

- 2 After fitting the marks on both lens and device, push in to insert.

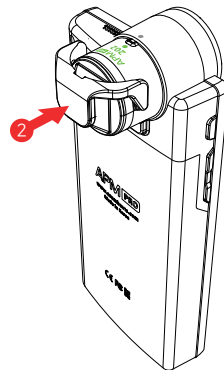
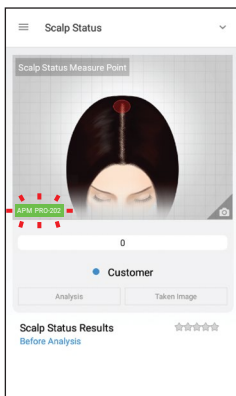

# Hair Loss Status X1 Lens

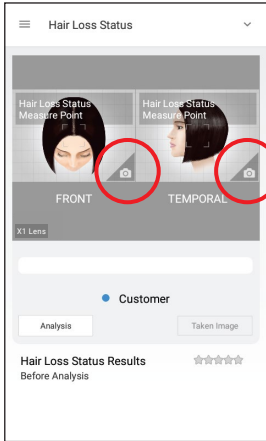

1 Touch  button to activate camera mode.



2 Put the camera onto the hair and touch  button to capture the image.

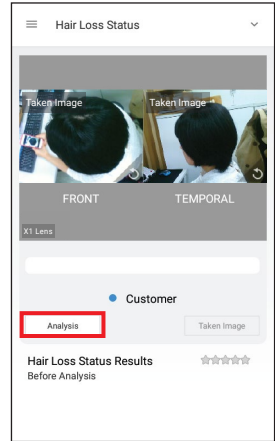

3 Touch "Analysis" to check analysis result.

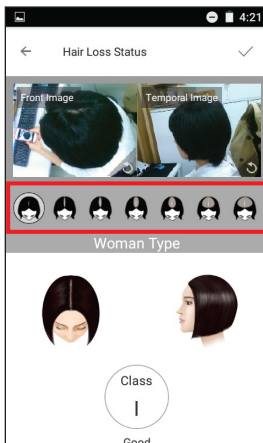

4 Then select the type which is similar with your hair loss shape.

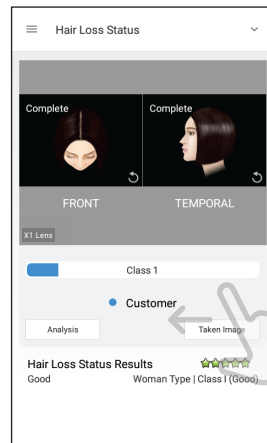

5 Check the result. And swipe to next step.

# Scalp Status

APM PRO-202

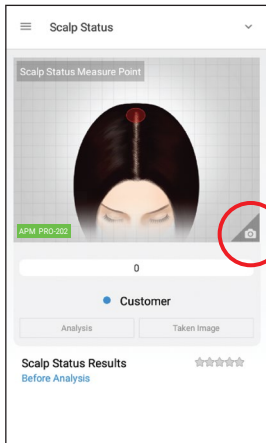

1 Touch  button to activate camera mode.



2 Put the camera onto the hair and touch  button to capture the image.

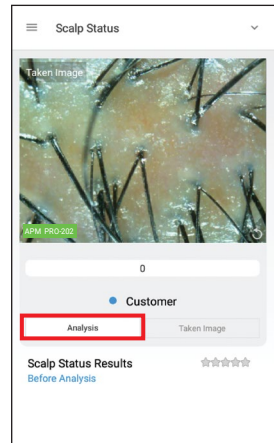

3 Touch "Analysis" to check analysis result.

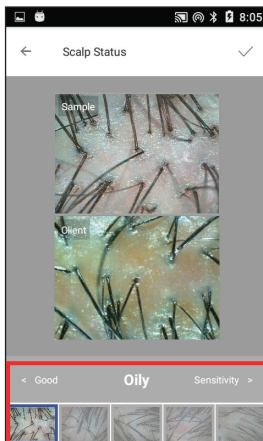

4 Among the samples, choose the one which is similar with your image.

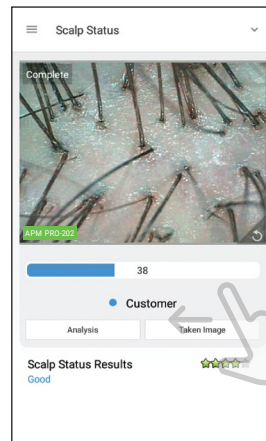

5 Check the result. And swipe to next step.

# Hair Density

APM PRO-202

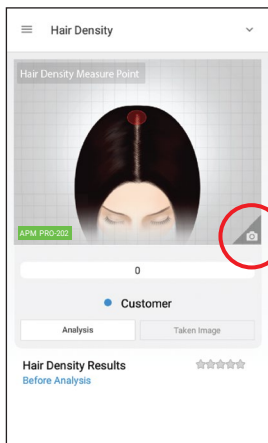

1 Touch  button to activate camera mode.

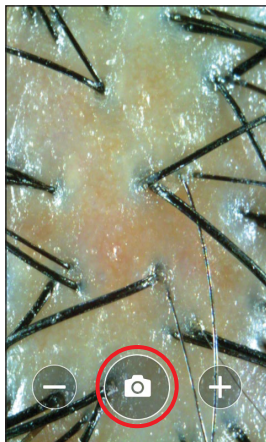

2 Put the camera onto the hair and touch  button to capture the image.

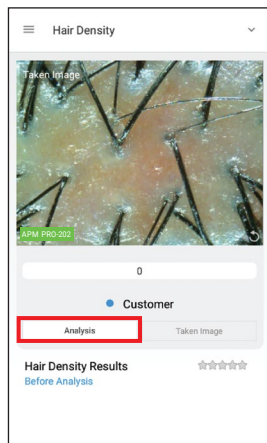

3 Touch "Analysis" to check analysis result.

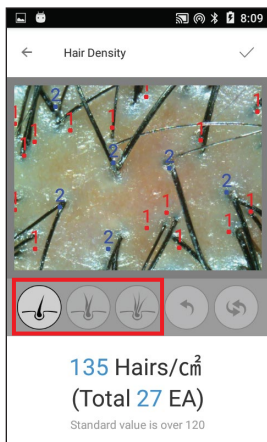

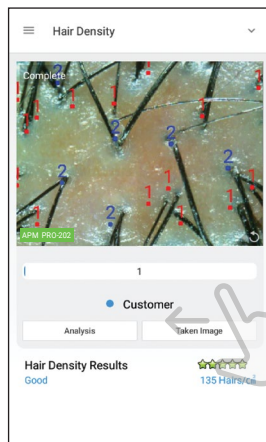

4 Count the hair number in the image.

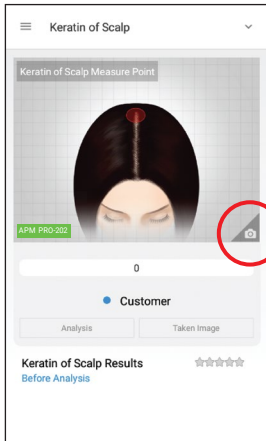

5 Check the result. And swipe to next step.

# Keratin of Scalp APM PRO-202



1 Touch  button to activate camera mode.



2 Put the camera onto the hair and touch  button to capture the image.

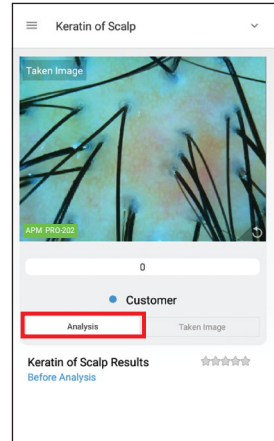

3 Touch "Analysis" to check analysis result.

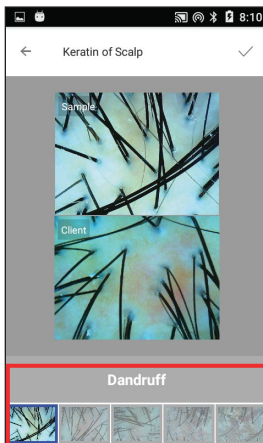

4 Among the samples, choose the one which is similar with your image.

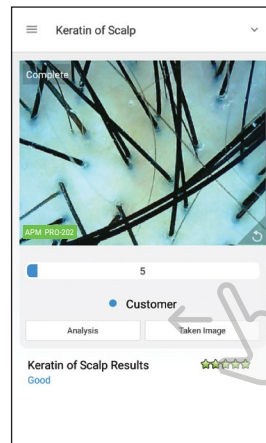

5 Check the result. And swipe to next step.

# Exposure of Scalp's Vessel

APM PRO-202

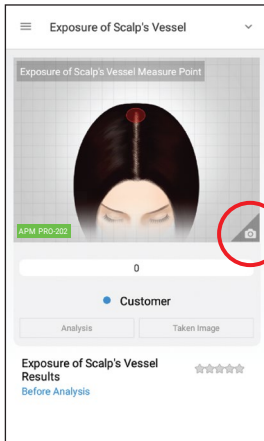

1 Touch  button to activate camera mode.

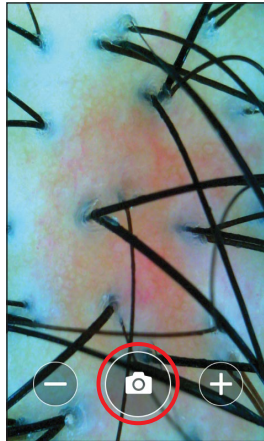

2 Put the camera onto the hair and touch  button to capture the image.

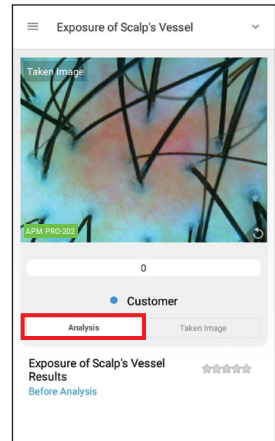

3 Touch "Analysis" to check analysis result.

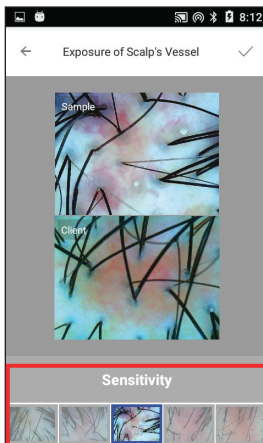

4 Among the samples, choose the one which is similar with your image.

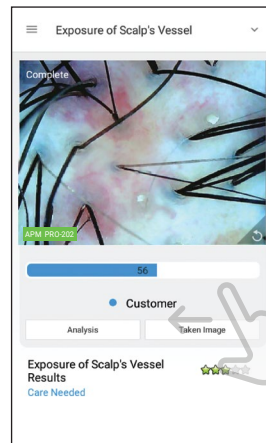

5 Check the result. And swipe to next step.



# Taking off the lens

APM PRO-203

- 1 Press the lens module change button which located below of the lens part.

- 2 The lens will be able to pull out.



Hair lens  
(APM PRO 203)

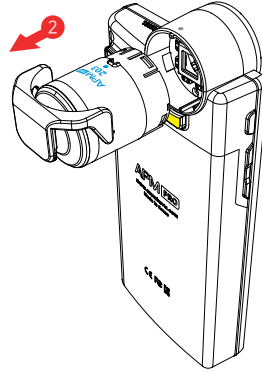
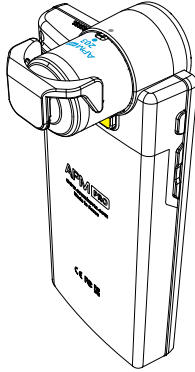

# Inserting lens

- 1 Until the correct lens is inserted, lens indicating label will blink.

- 2 After fitting the marks on both lens and device, push in to insert.

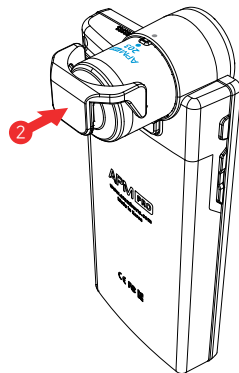
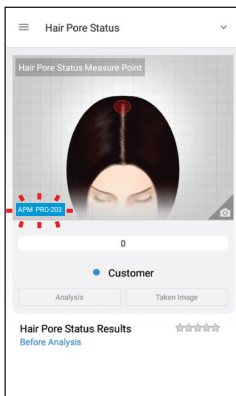

# Hair Thickness

APM PRO-203

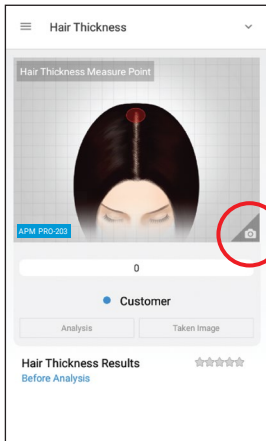

1 Touch  button to activate camera mode.



2 Put the camera onto the hair and touch  button to capture the image.

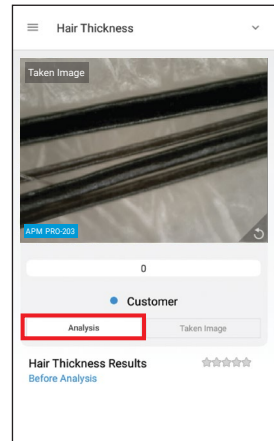

3 Touch "Analysis" to check analysis result.

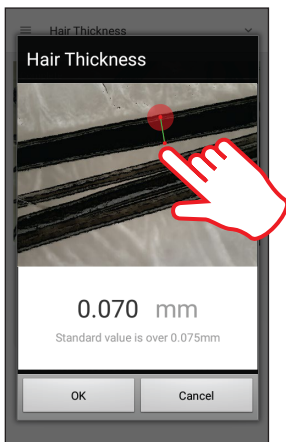

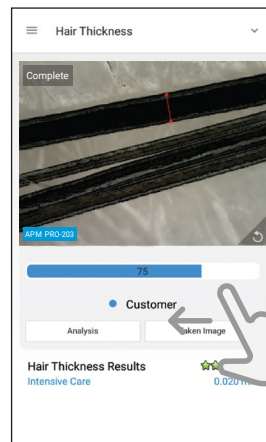

4 Choose one hair and touch little bit down side of the hair. Then touch little bit upside of the hair. It will make a green line to measure the thickness.  
(If the line is not correct, please try again)



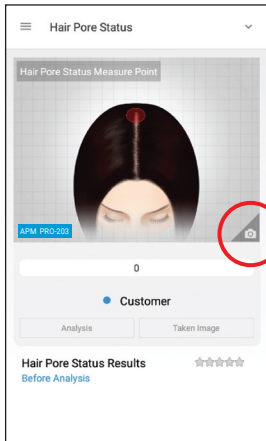

5 Check the result.  
And swipe to next step.

# Hair Pore Status APM PRO-203

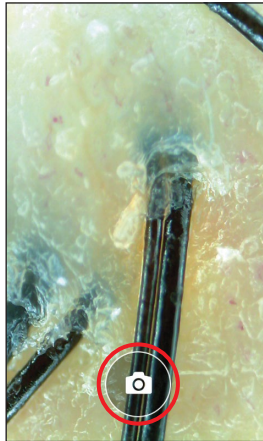

1 Touch  button to activate camera mode.



2 Put the camera onto the hair and touch  button to capture the image.

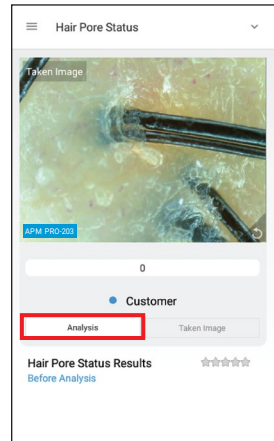

3 Touch "Analysis" to check analysis result.

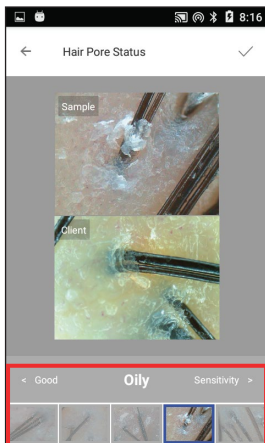

4 Among the samples, choose the one which is similar with your image.

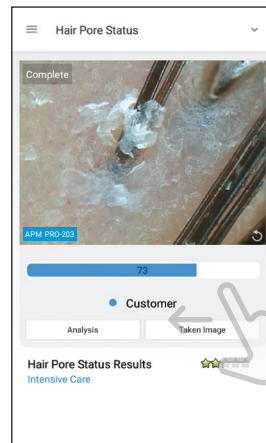

5 Check the result. And swipe to next step.

# Taking off the lens

APM PRO-204

- 1 Press the lens module change button which located below of the lens part.
- 2 The lens will be able to pull out.

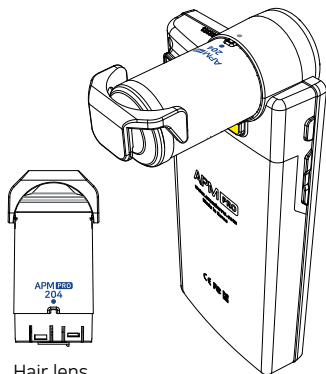

Hair lens  
(APM PRO 204)

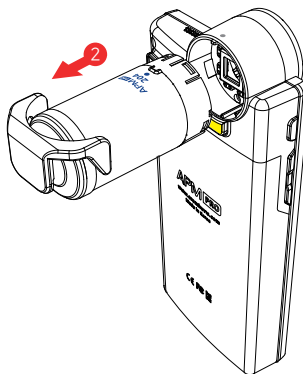

# Inserting lens

- 1 Until the correct lens is inserted, lens indicating label will blink.
- 2 After fitting the marks on both lens and device, push in to insert.

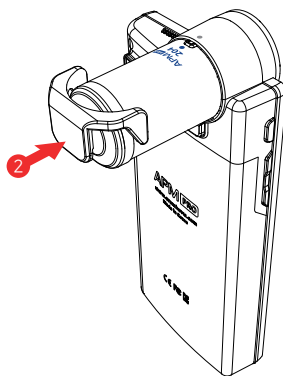
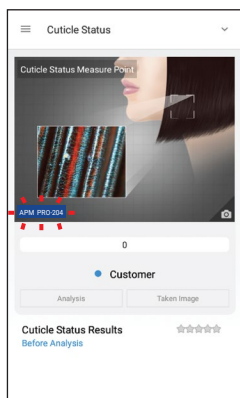

# Cuticle Status

APM PRO-204

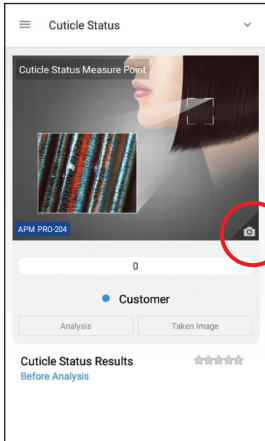

1 Touch  button to activate camera mode.



2 Put the camera onto the hair and touch  button to capture the image.

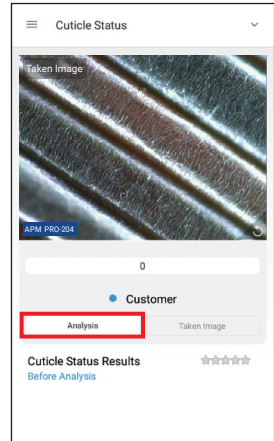

3 Touch "Analysis" to check analysis result.

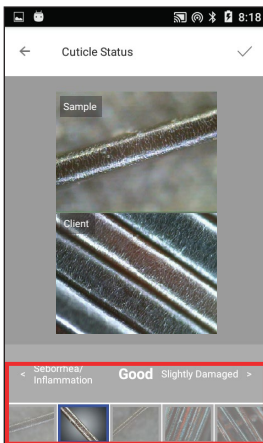

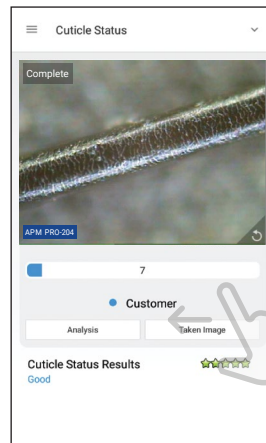

4 Among the samples, choose the one which is similar with your image.



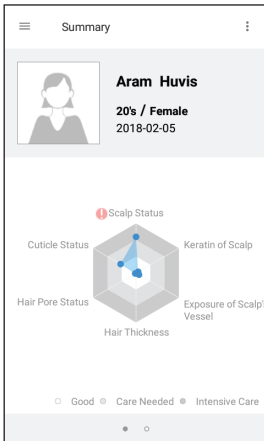

5 Check the result. And swipe to next step.

# Summary

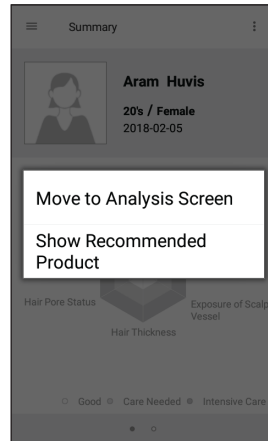

① Check the result. Touch  button or each parameter's name on pentagon graph.



② Once you select "Show Recommended Product", product image will pop up as .



③ Available to check product image.

# Send Result - Email

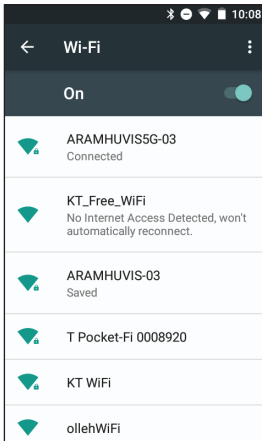

1 Before sending Email, the device shall be connect-  
ed to Wi-Fi.

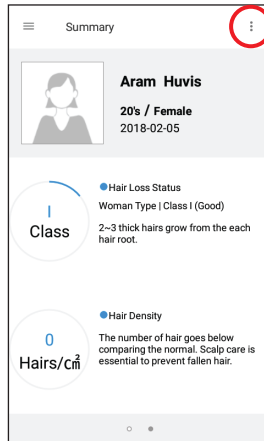

2 Touch **:** button.

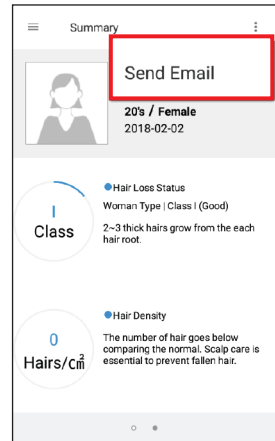

3 Go to "Send Email".

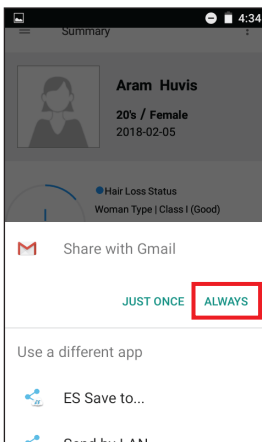

4 Select "Gmail" and "  
always".

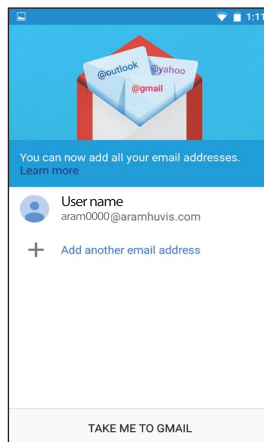

5 Select the mail account  
to register on the list.

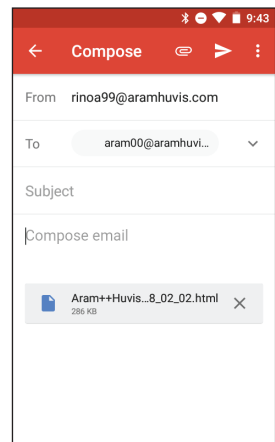

6 After selected sender's  
mail address, put receiver's  
mail address. Then touch  
"Send" button.

# Mirroring

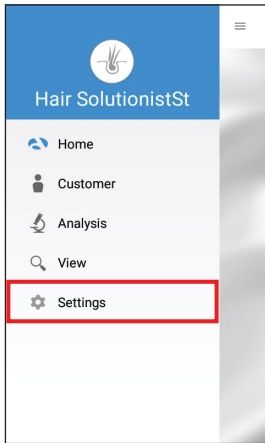

1 Go to "Settings".

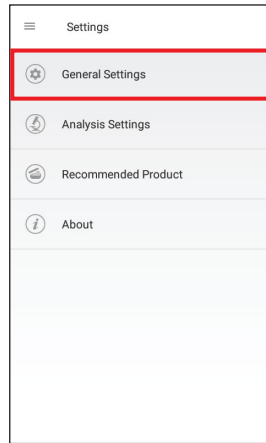

2 Go to "General Settings".

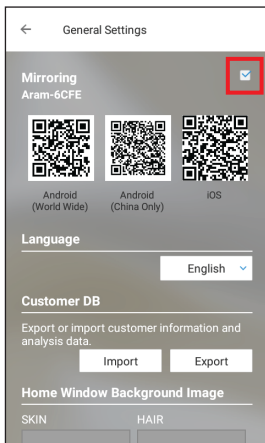

3 Set the mirroring option "On".



4 Capture QR code using QR code reader app. Automatically moved to App store.



# Mirroring

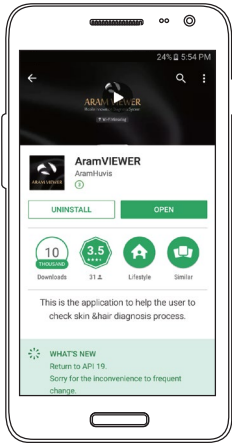

5 Install "Aram VIEWER".



6 Then, go to "Wi-Fi Setting".

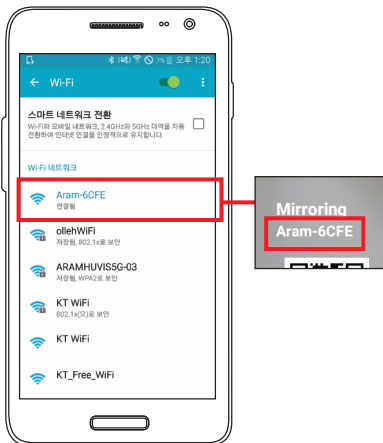

7 In your mobile device go to Wi-Fi setting. Then find SSID and connect it.



8 Mirroring will be started.

# View Mode

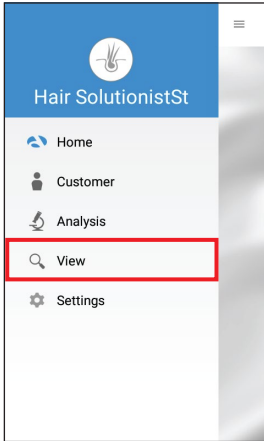

① Touch "View".

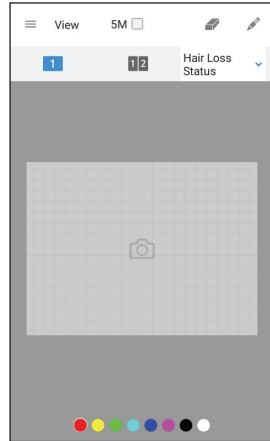

② In view mode, it is able to take pictures with capture button.

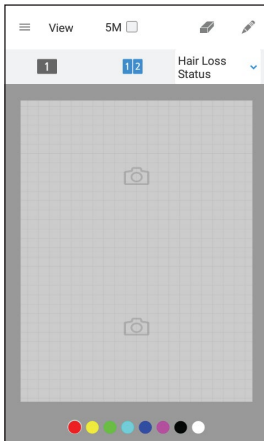

③ The user can select analysis parameter to take pictures in proper mode.

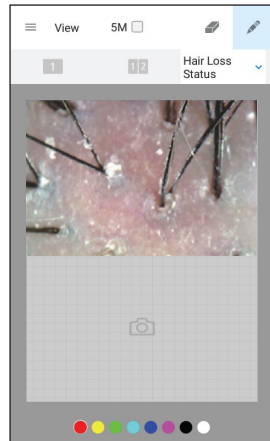

④ The user can mark the defect or concern according to the image with note function.

# Troubleshooting & FAQ

① I cannot turn on the device.

Connect and charge the device (or the battery) using the adaptor provided the supplier.  
(The battery charging indicator will be shown on the system main page.)

② The using time of the battery is different from the manual.

The battery using time will be shorten if you put the charged battery in a low or high temperature.  
The battery using time varies in service type, using environment, using period of the battery.  
The battery is consumed without using the device, and the battery using time will be shorten if you use additional functions of the device.

③ The device turns on but the diagnosis doesn't work.

Check the smart card is correctly inserted (SD card slot on the button of the device.)

④ There are dust on the device.

Clean the dust by using a smooth fabric. Do not use benzene, alcohol, and a synthetic detergent.

⑤ A "force close" message appears on the screen.

The repetition of commands can trigger a bug. Sometimes there may be a brief delay before the command is completed. Do not repeat/multiply the tasks as the device will no longer be able to follow them.

⑥ I cannot connect to Wi-Fi.

Check the connection status on setting page.

Try to connect to another Wi-Fi.

Bluetooth : check the pairing status and try to re-pair the device with host device.

⑦ The touchscreen doesn't react to my finger commands.

Before using for the first time remove the protective plastic film.

# Troubleshooting & FAQ

## 8 I cannot connect to Blue-tooth.

Make sure to use the Bluetooth hosting devices that have Bluetooth certified with the logo. You may need an external Bluetooth dongle for those devices that do not have Bluetooth feature. Bring the device closer with the Bluetooth hosting device.

Try to re-pair the device with host device.

The password of pairing is "0"(number).

\* Blue-tooth function is not allowed to use in IOS device without APPLE'S official permission.

## 9 The screen was turned off.

Press the on/off button to turn on the screen.

The device has a power save function that turns the screen off after 1 minute.

For the setting, please refer to Page 8.

## 10 I can see the black screen only during measurement.

Check the LED light inside lens on the head part when you try to measure.

If you cannot see the light, please contact the customer service via email or phone call.

## 11 The image is not clear.

Tap the screen while capturing focus.

## 12 I cannot update the diagnosis application.

Check the network connection. The update process can be done after connecting to Wi-Fi.

# Warranty

- ① The product undergoes strict quality management and inspection process before production and introduction to market.
- ② In case of functional or operational defect occurs under normal condition of use within 10 days after purchase, we will repair it for free or replace in new product.
- ③ When this product goes out under the normal use, we will repair it free of charge under warranty.
- ④ Please keep the warranty card when you ask for repair service.
- ⑤ Customer needs to pay repair charge after warranty runs out.
- ⑥ For this product, warranty period is 14 months from the Invoice date.
- ⑦ Cost  
Within warranty : Sending delivery(Buyer), repair cost and returning delivery(Aram)
  - If the product is broken by user's fault, repair cost could be charged.
  - After warranty : Sending delivery and repair cost(Buyer), returning delivery(Aram)
- ⑧ How to send :
  - As sending a present from person to person by EMS or FEDEX.  
(Do not write the company name)
  - Total value should be under US \$ 99.(Write non-commercial value)

# Warranty

Service request form			
Date of purchase	/	/	Company
Contact person			
Address :			
Tel :			
Product name, serial No :			
Problems :			

SHIPPING ADDRESS :

#801 Byucksan Technopia, 560, Dunchon-daero, Jungwon-gu, Seongnam-si,  
Gyeonggi-do, 13230 Republic of Korea

Tel: 070-4687-1712 / Fax: 031-732-6330 / Email: support@aramhuvivis.com  
<http://www.aramhuvivis.com>

# Memo

---



**HEAD OFFICE**

#401~402 Bundang Seoul National University Hospital Health Care Innovation Park, 172, Dolma-ro, Bundang-gu, Seongnam-si, Gyeonggi-do, 13605 Republic of Korea

**PRODUCTION DIVISION & FACTORY**

#909 Byucksan Technopia, 560, Dunchon-daero, Jungwon-gu, Seongnam-si, Gyeonggi-do, 13230 Republic of Korea

Tel: 070-4687-1712 / Fax: 031-732-6330 / Email: [info@aramhuvis.com](mailto:info@aramhuvis.com)  
<http://www.aramhuvis.com>