

API-202

User Manual



Contents

A. Components	2
<hr/>	
B. H/W Parts	
i. Both Sides	3
ii. Settings	4
iii. Battery / Light Functions	6
<hr/>	
C. System Settings	
i. Download & Install	7
ii. How to connect with the program	8
<hr/>	
D. Program Settings	9
i. Device Certification	10
<hr/>	
E. Application	
i. Start Analysis	12
ii. Full Analysis	
CRM	13
Hair Loss Status	14
Scalp Status	15
Hair Density	16
Keratin of Scalp	17
Exposure of Scalp's Vessel	18
Hair Thickness	19
Hair Pore Status	20
Summary	21
iii. View Mode	22
<hr/>	
F. Warranty	23

※ Notes on use

- The images of this manual can be different with the actual things.
- The information contained in this manual and future improvements are subject to change without notice.
- The latest version of the manual will be updated at the below link.
<http://www.aramhuvis.com/downloads>

Components

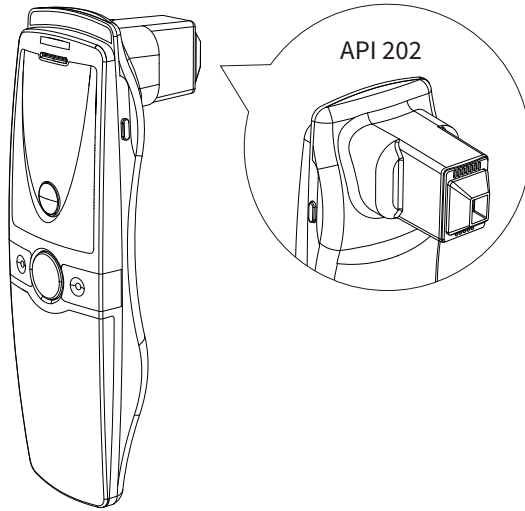

Main body with hair lens

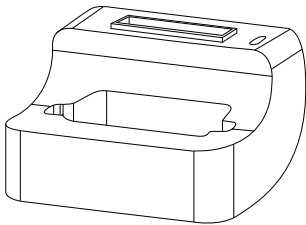

Cradle

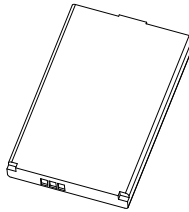

Battery

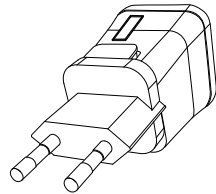

Charger

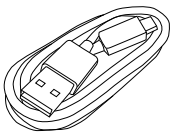

USB cable



Cleaning cloth



Manual

H/W Parts

Both Sides

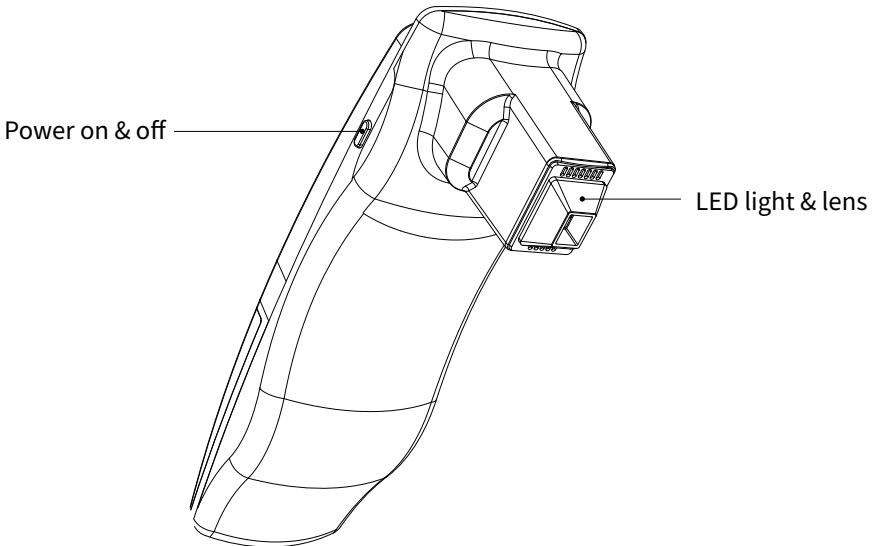
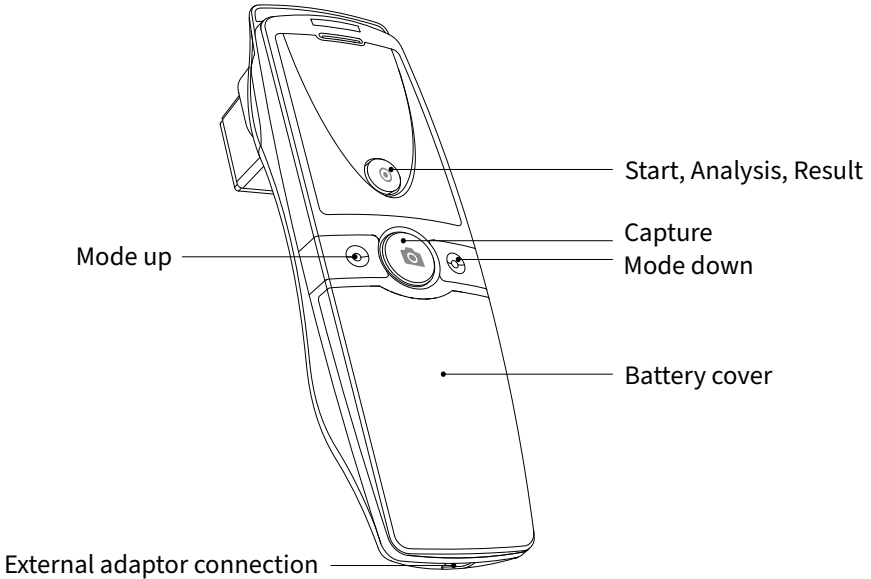

H/W Parts

Settings

Insert the battery

- 1 Open the battery cover by pushing it down with finger.
- 2 Insert the battery and gently press the battery into place.
- 3 Close the cover.

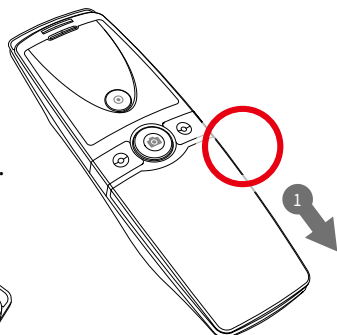
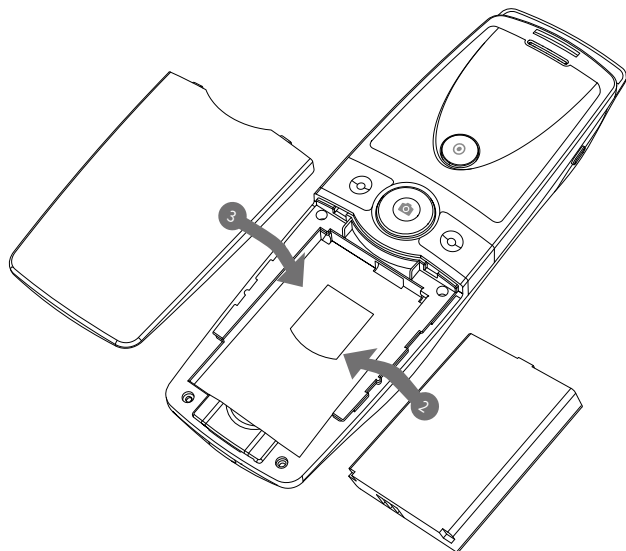

To turn on the power

- 1 Press and hold "power" button.
- 2 "Indicate LED" starts twinkling in blue light.
When it stops, the device is ready to use.

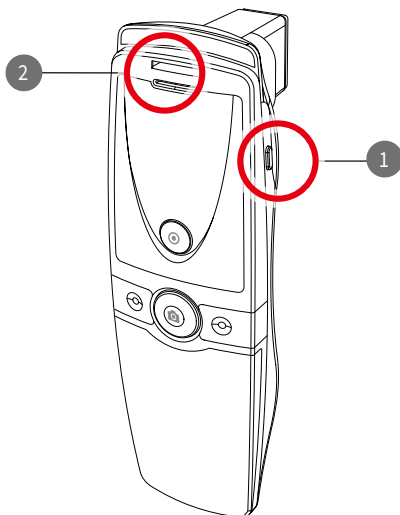

To turn off the power

- 1 Press and hold "power" button.
- 2 "Indicate LED" will be turned off.

H/W Parts

Settings

Charger can be used for American type & European type.
The default is European type.

- 1 Push the plug up.

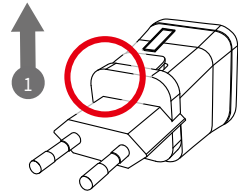

- 2 Then 220V European type is disassembled and you can see the 110V-220V American type inside of the charger.

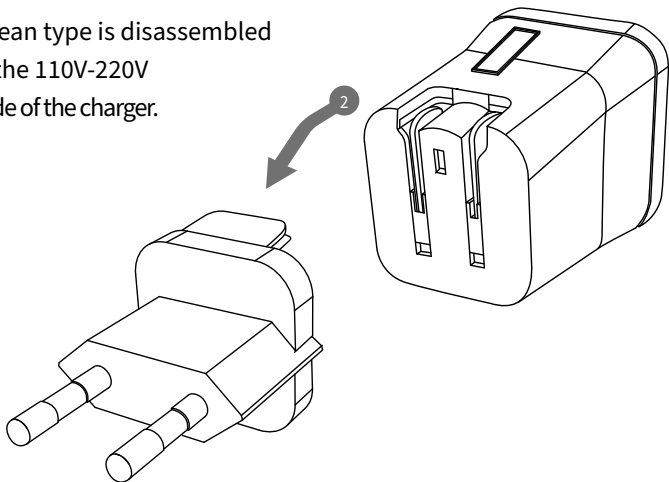

- 3 Choose the one you want to use and connect USB cable in adaptor.

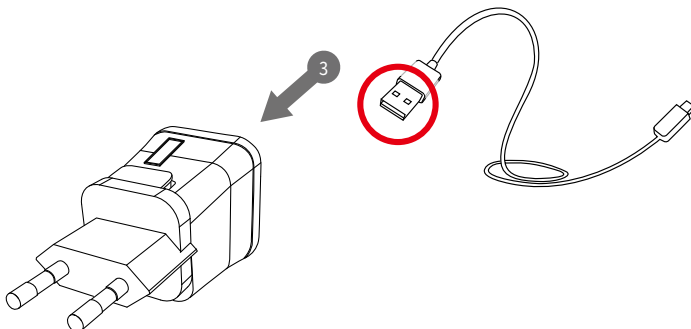

H/W Parts

Battery / Light Functions

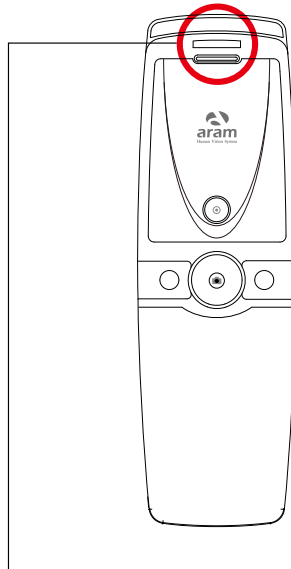

Battery / Light Functions

CAMERA POSITON	STATUS	LED	
In use	While Turning it on	Flashing blue light	● ●
In use	Connected	Blue light	●
In use	Low Battery	Flashing Red/blue light	● ●
In use	While turning it off	Flashing Red light	● ●
Plugged to the base	Charging	Red light	●
Plugged to the base	Fully charged (140 minutes)	Blue light	●

System Settings

Download & Install

PC User

- 1 Go to link on the browser as below.
<http://www.aramhuvis.com/downloads>
- 2 Install the program.

Tablet device or Smartphone user

- 1 iOS : Go to "App Store" and search "Solutionist" to download the program.
- 2 Android : Go to "Google Play Store" and download it.

System Settings

How to connect with program

- 1 First of all, check the Wi-Fi name and password which is described at back side of battery cover.
- 2 Wi-Fi name & password must be same and the format is "API_XXXX".
- 3 Turn on the device.
- 4 While turning on the device, prepare PC, Tablet, Smartphone to run the S/W.
- 5 Once "API" device is turned on, please go to network setting to set up the Wi-Fi connection.
- 6 Among Wi-Fi lists, find "API_XXXX" and select it.
- 7 When above code is connected, run the program "Solutionist".
- 8 To check working properly, please check the program and see the left below side.
- 9 If it is correctly set up, you can see the blue light of Wi-Fi singal.

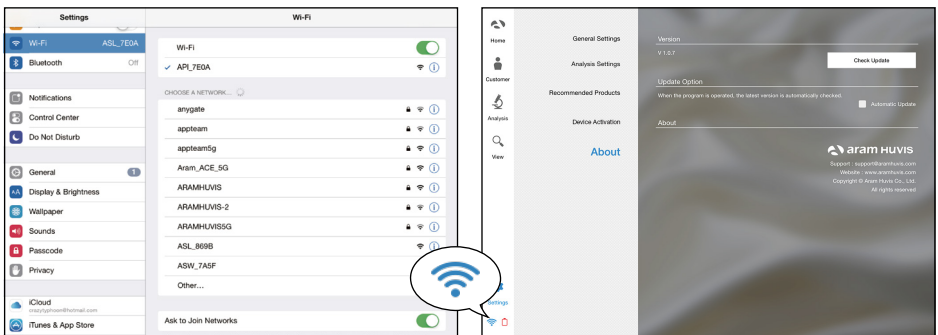
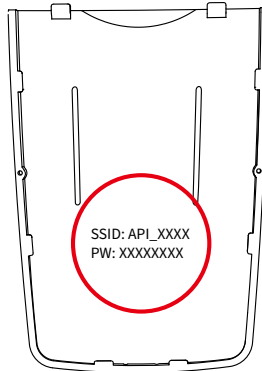

Program Settings

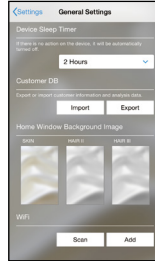
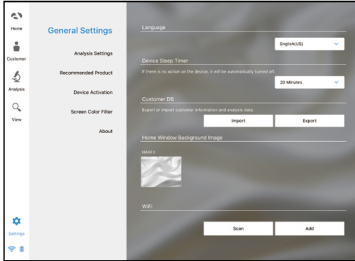

- 1 **General Settings**
Change the language, analysis mode and etc.

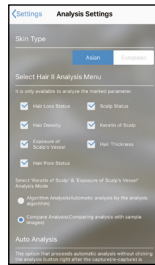
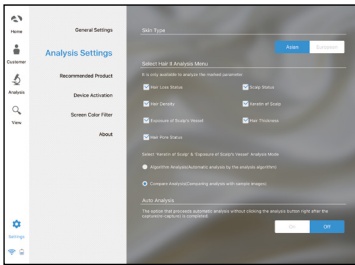

- 2 **Analysis Settings**
Set up the HAIR type and analysis parameter.

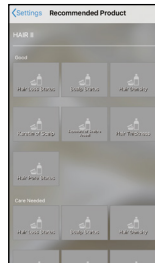
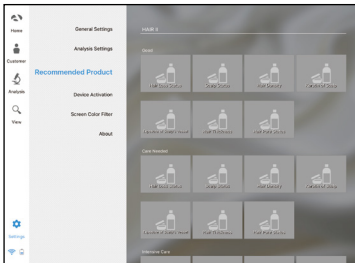

- 3 **Recommended Products**
Available for each analysis result.

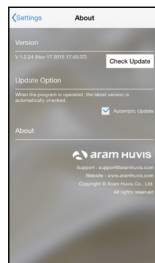
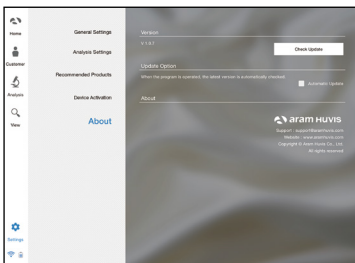

- 4 **About**
Check the current version and update is available in Wi-Fi connection.

Program Settings

Device Certification

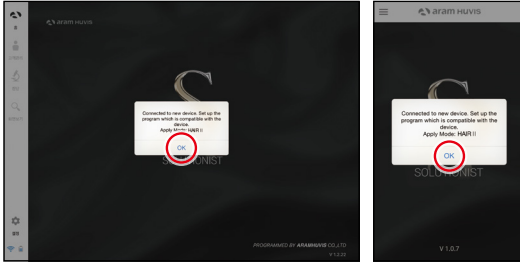

- 1 Solutionist program includes three programs. But when you start “Solutionist” program with API-202 device you can see the pop message saying that the program is compatible with only “HAIR II ” device. Touch “OK” button.

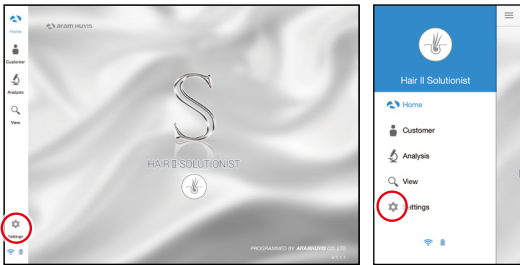

- 2 Then you will see now only “HAIR II ” program is activated. On main menu, touch “Settings”.

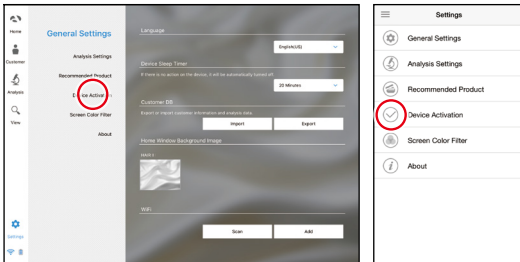

- 3 Among the menu, please select “Device Activation”.

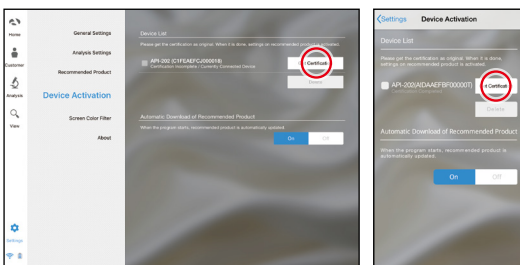

- 4 There is a device model name with serial code. Please touch “Get Certification” to register the device in program.

Program Settings

Device Certification

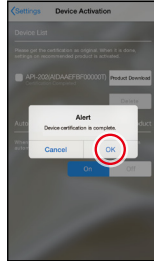
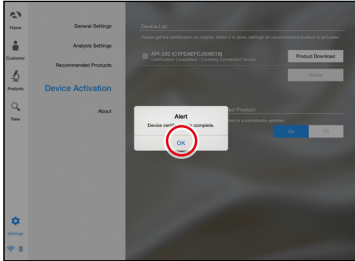

- 5 Device certification is complete. Please touch “OK” button.

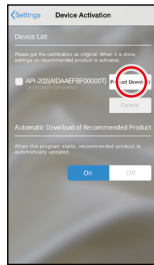
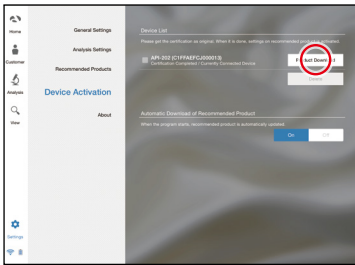

- 6 When it is done, you could touch “Product Download” button to load in server.

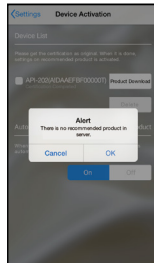
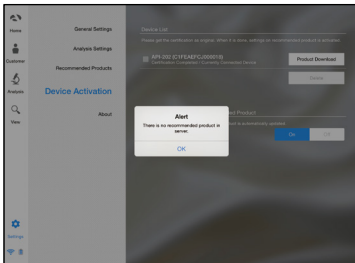

- 7 If you have the recommended product data in server, the product will be downloaded by clicking “Product download”. If you do not have the recommended product data, you can see the message as left image.

Application

Start Analysis

- 1 Touch "Analysis" to start.

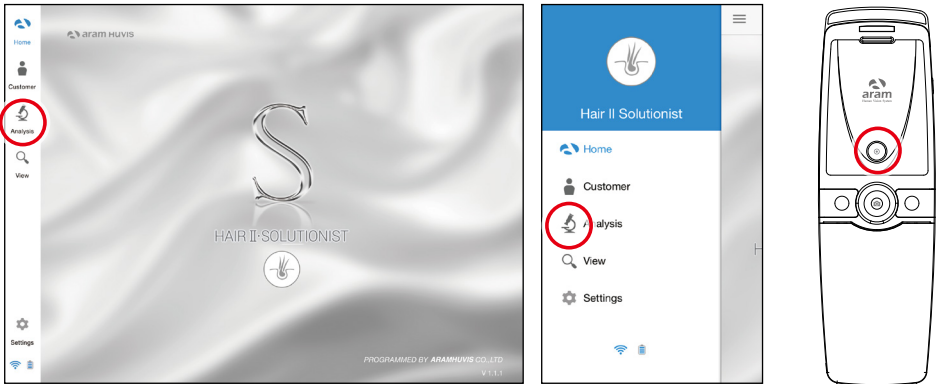

Remote Control (Only Tablet)

- 1 During analysis, you can control the device in "Solutionist" program.
- 2 In screen, touch "Control Menu On" to activate "Remote".
- 3 You can make use of this function in all analysis pages.

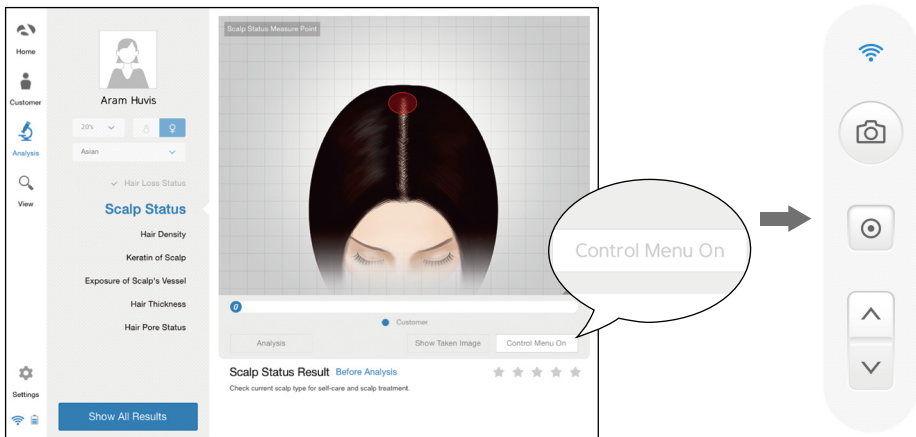

Application

CRM

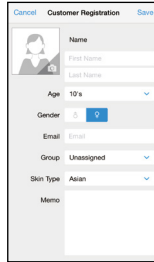
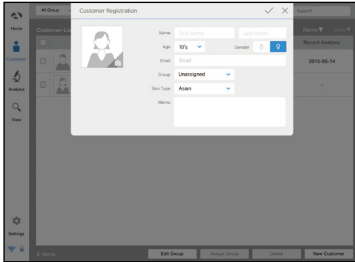

- 1 Input the information.
- full name, email address, gender and age group

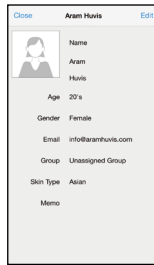
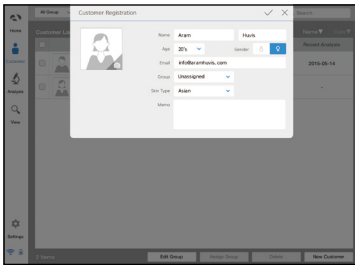

- 2 Take picture of customer's face with built-in camera or use the picture you already have in device.

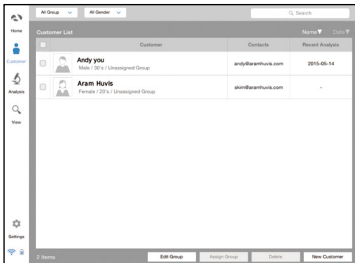

- 3 Among the customer lists, select the client to check or start analysis.

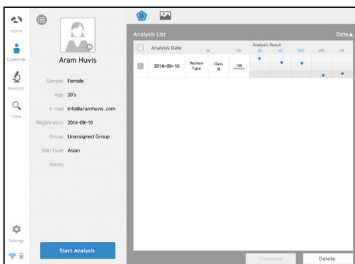

- 4 Check the customer information and analysis result list.

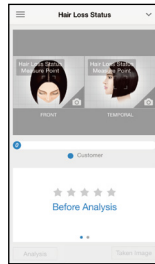
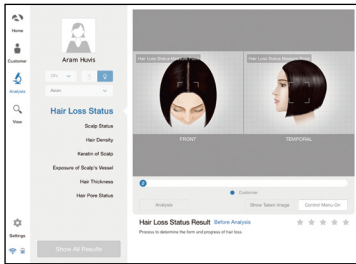

Application

Hair Loss Status

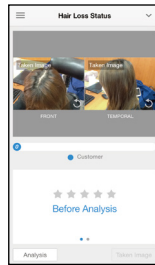
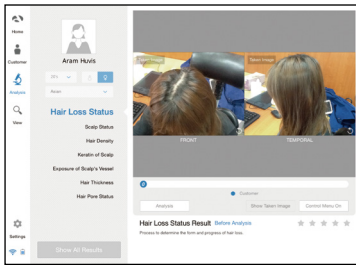
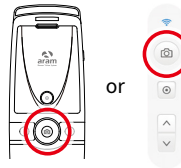

- 1 Touch  button to activate the built-in camera.



- 2 Take pictures of "Front" and "Temporal" head by  button and touch  button.

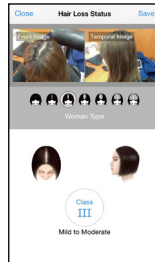
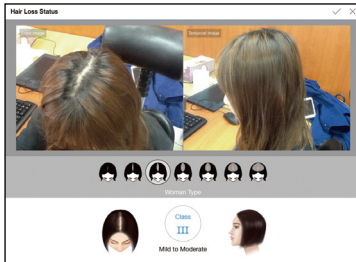
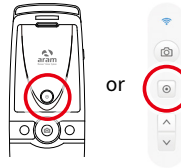

- 3 Then select the type which is similar with your hair loss shape.

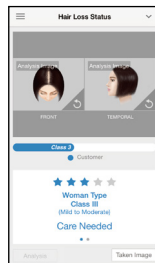
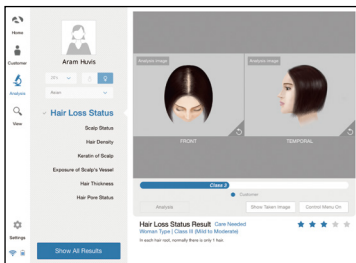

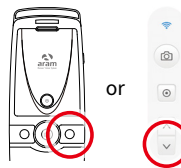

- 4 The result will appear. To analyze the next step, touch the below button.



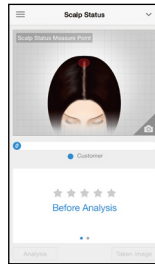
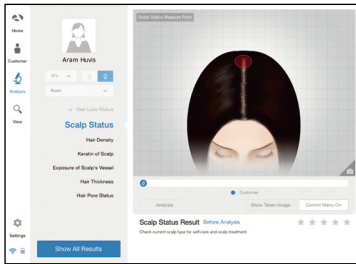

Application

Scalp Status

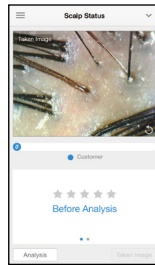
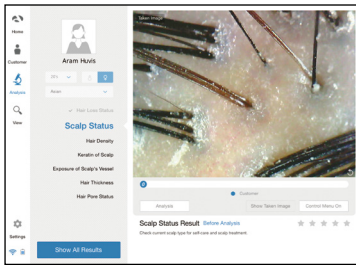
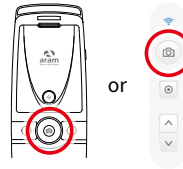

- 1 Touch  button to activate the camera.



- 2 Take pictures of the scalp by  button and touch  button.

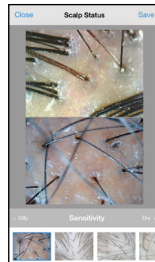
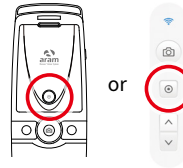

- 3 Among the samples, choose the one which is similar with your image.

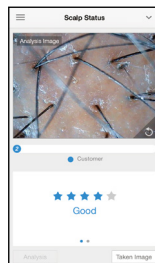
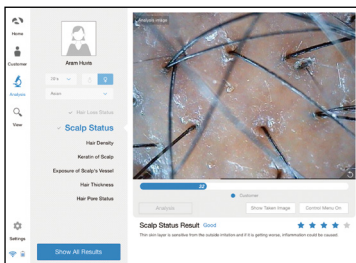

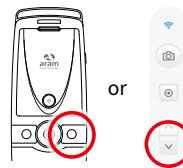

- 4 The result will appear. To analyze the next step, touch the below button.



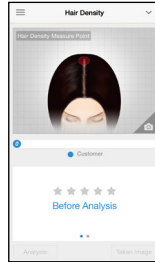
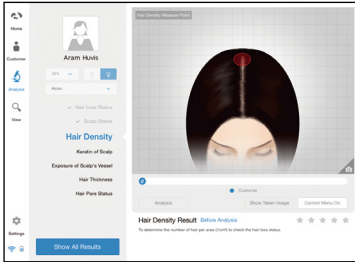

Application

Hair Density

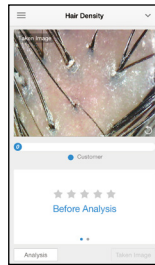
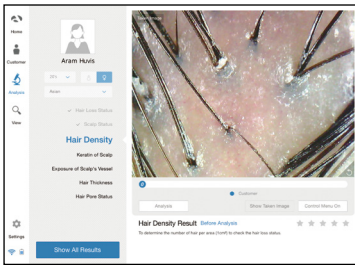
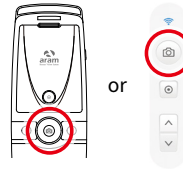

1 Touch  button to activate the camera.



2 Take pictures of the scalp by  button and touch  button.

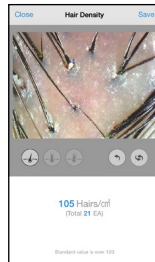
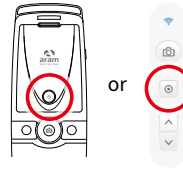

3 Count the hair number in the image.

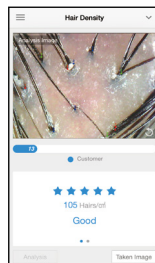
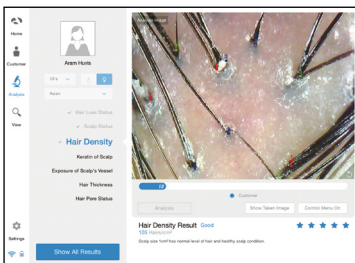

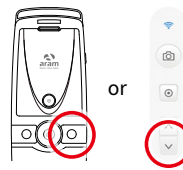

4 The result will appear. To analyze the next step, touch the below button.



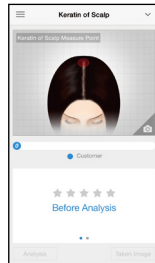
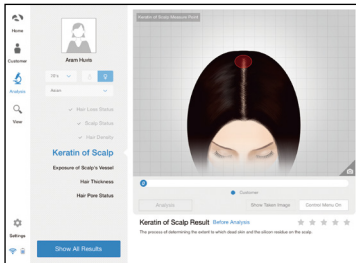

Application

Keratin of Scalp

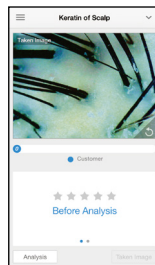
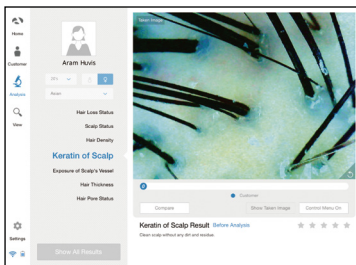
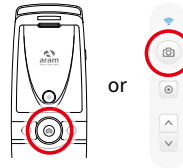

- 1 Touch  button to activate the camera.



- 2 Take pictures of the scalp by  button and touch  button.

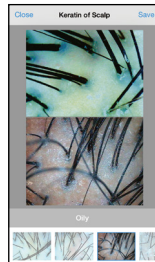
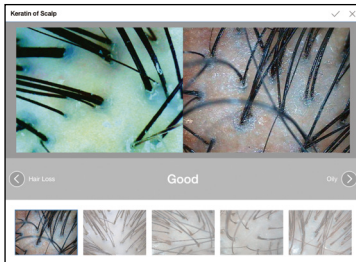
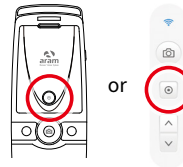

- 3 Among the samples, choose the one which is similar with your image.

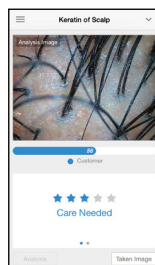
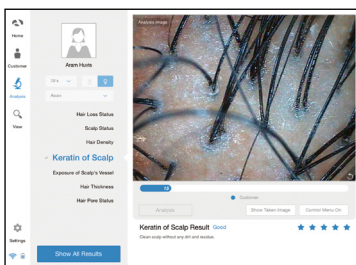

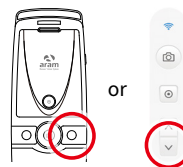

- 4 The result will appear. To analyze the next step, touch the below button.



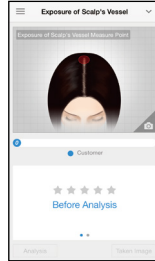
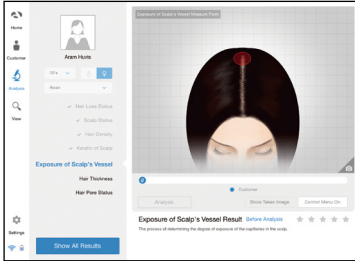

Application

Exposure of Scalp's Vessel

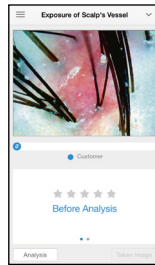
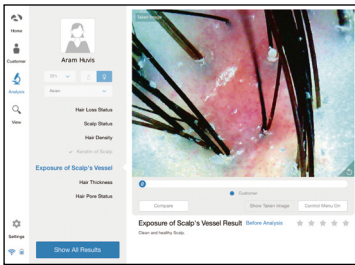
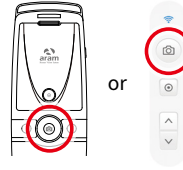

- 1 Touch  button to activate the camera.



- 2 Take pictures of the scalp by  button and touch  button.

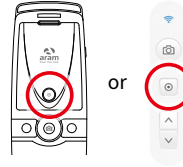

- 3 Among the samples, choose the one which is similar with your image.

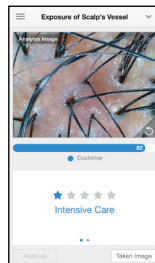
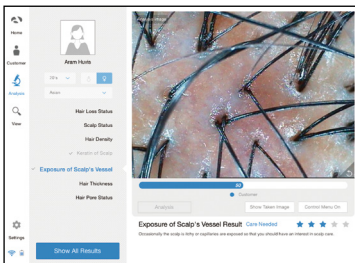

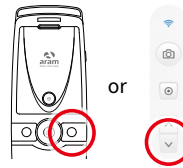

- 4 The result will appear. To analyze the next step, touch the below button.



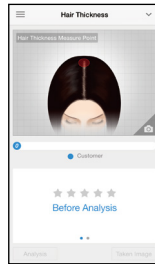
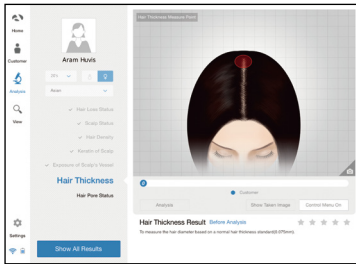

Application

Hair Thickness

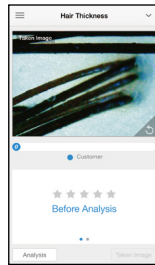
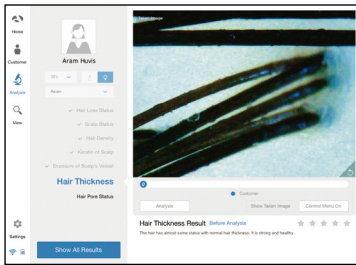
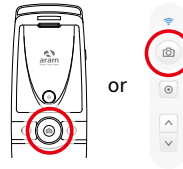

- 1 Touch  button to activate the camera.



- 2 Take pictures of the hair by  button and touch  button.

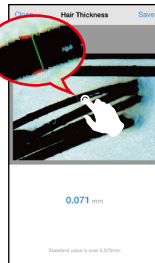
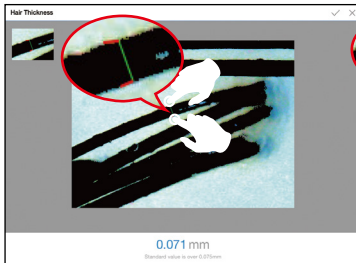
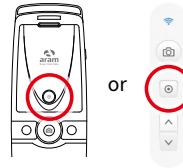

- 3 Choose one hair and touch little bit down side of the hair. Then touch little bit upside of the hair. It will make a green line to measure the thickness. (If the line is not correct, please try again)

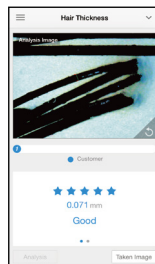
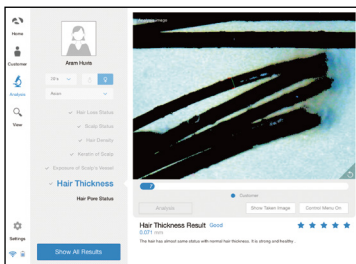

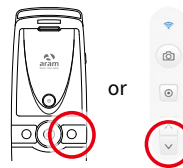

- 4 The result will appear. To analyze the next step, touch the below button.



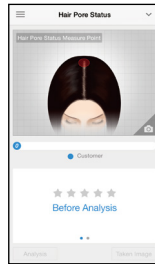
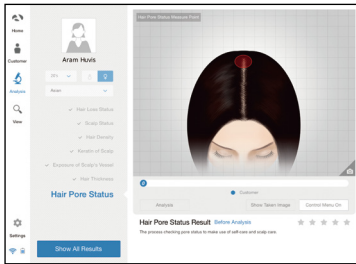

Application

Hair Pore Status

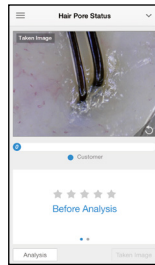
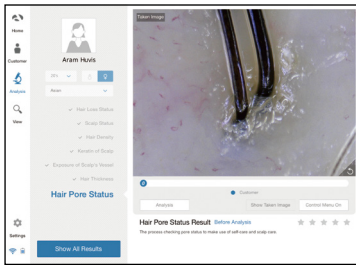
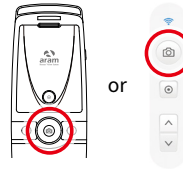

- 1 Touch  button to activate the camera.



- 2 Take pictures of the pore by  button and touch  button.

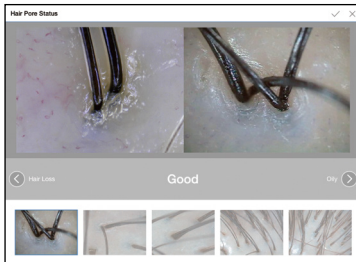
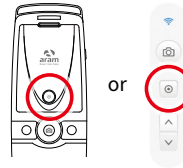

- 3 Among the samples, choose the one which is similar with your image.

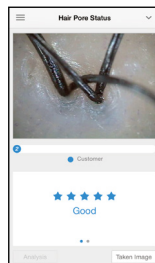
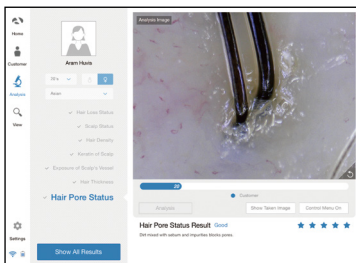

- 4 The result will appear. To analyze the next step, touch the below button.



Application Summary

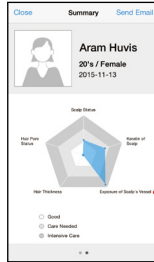
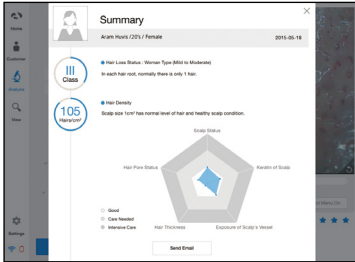

1 Check the result.

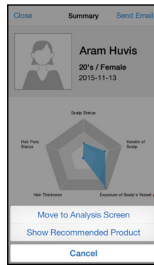
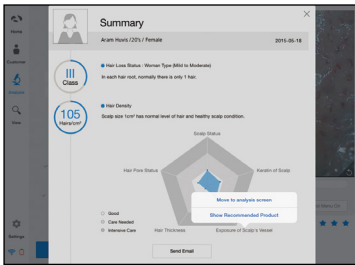

2 Touch **1** button or each parameter's name on pentagon graph. Once you select "Show Recommended Product", product image will pop up as **3**.

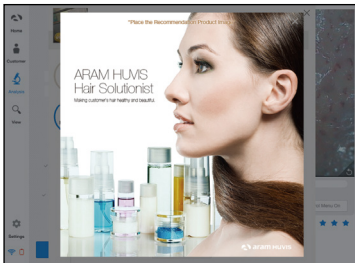

3 Available to check product image.

Application

View Mode

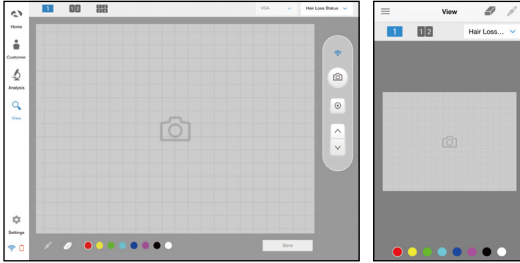

- 1 In view mode, it is able to take pictures with capture button in many times.

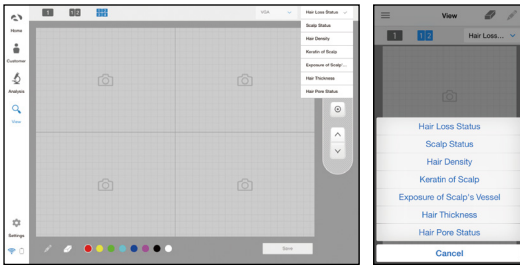

- 2 The user can select analysis parameter to take picture.

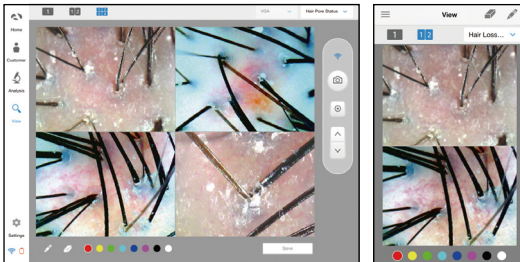

- 3 In one screen, you can see 4 different images maximum.

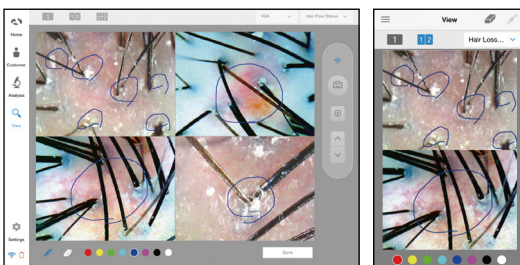

- 4 The user can mark the defect or concern according to the image with note function.

Warranty

- ① The product undergoes strict quality management and inspection process before production and introduction to market.
- ② In case of functional or operational defect occurring under normal condition of use within 10 days after purchase, we will repair it for free or replace in new product.
- ③ When this product goes out under the normal use, we will repair it free of charge under warranty.
- ④ Please keep the warranty card when you ask for repair service.
- ⑤ Customer needs to pay repair charge after warranty runs out.
- ⑥ For this product, warranty period is 14 months from the Invoice date.

⑦ Cost

Within warranty : Sending delivery(Buyer), repair cost and returning delivery(Aram).

- If the product is broken by user's fault, repair cost could be charged.

After warranty : Sending delivery and repair cost(Buyer), returning delivery(Aram)

⑧ How to send :

- As sending a present from person to person by EMS or FEDEX.

(Do not write the company name)

- Total value should be under US \$99.(Write non-commercial value)

Warranty

Service request form			
Date of purchase	/	/	Company
Contact person			
Address :			
Tel :			
Product name, serial no :			
Problems :			

Shipping address:

560, Dunchon-daero, Jungwon-gu, Seongnam-si, Gyeonggi-do, 13230, Rep. of KOREA

E-mail : support@aramhuvis.com

Tel : +82 70 4687 1712 / Fax : +82 31 732 6330

MEMO

MEMO



HEAD OFFICE

#401~402 Bundang Seoul National University Hospital Health Care Innovation Park, 172, Dolma-ro, Bundang-gu, Seongnam-si, Gyeonggi-do, 13605 Republic of Korea

PRODUCTION DIVISION & FACTORY

#909 Byucksan Technopia, 560, Dunchon-daero, Jungwon-gu, Seongnam-si, Gyeonggi-do, 13230 Republic of Korea

Tel: 070-4687-1712 / Fax: 031-732-6330 / Email: info@aramhuvis.com
<http://www.aramhuvis.com>